

PAPER • OPEN ACCESS

Investigation of the interfacial adhesion of glass bead-filled multicomponent injection moulded composites

To cite this article: A Suplicz *et al* 2020 *IOP Conf. Ser.: Mater. Sci. Eng.* **903** 012049

View the [article online](#) for updates and enhancements.

Investigation of the interfacial adhesion of glass bead-filled multicomponent injection moulded composites

A Suplicz¹, R Boros¹ and O V Semperger¹

¹ Department of Polymer Engineering, Faculty of Mechanical Engineering, Budapest University of Technology and Economics, Műegyetem rkp. 3., H-1111 Budapest, Hungary

E-mail: suplicz@pt.bme.hu

Abstract. Polymeric materials are often combined with fillers and reinforcements, which modify their properties. The goal can be for example the improvement of thermal and mechanical properties or a reduction in costs. On the other hand, these materials can have negative effects too. In multicomponent injection moulding or in the case of products with weld lines, bonding problems can occur. In this research project, we analysed the effect of glass fibre and glass beads, and the most important technological parameters, melt temperature and holding pressure on the bonding strength between multicomponent injection moulded parts. The test samples were produced with a special injection mould, and the tear-off tests were performed on a tensile testing machine with a grip we developed.

1. Introduction

In the last decades, the plastic industry has been one of the most dynamically developing sectors. In 2018, more than 350 million tons of polymer material was produced. The most important and versatile polymer processing method is injection moulding, which is supported by various technological solutions, processing techniques and a great variety of raw materials [1, 2].

Polymeric materials are often compounded with additives, fillers and reinforcements as many industries, such as the automotive or medical industry have strict requirements for plastics. In most cases, the goal of using additives is to improve mechanical properties, colour the polymer or simply decrease costs. The additives can have negative effects, too. During injection moulding, they can cause welding or bonding failures in multicomponent, overmoulded parts or in parts containing weld lines. This problems can decrease the lifetime of the parts [1, 3-8].

Interfacial adhesion is influenced by many factors. The theories are grouped in the literature into seven types: mechanical coupling (interlocking), diffusion, thermodynamic, electrostatic interaction, weak boundary layer, polarization and chemical bonding theory. The mechanical coupling theory means that the overmoulded material interlocks into the surface irregularities of the other part. According to the diffusion theory, adhesion forms when the two surfaces come into contact to each other at appropriate temperature and clamping pressure, and the macromolecules diffuse through the interface. In the thermodynamic theory, adhesion depends on the wettability of the materials. The strength of adhesion is affected by the surface energy, the chemical structure and the interactions of the components. Finally, the chemical bonds theory means that chemical bonds, like covalent bonds can be formed between the surfaces [9-10].



Adhesion between the components in overmoulding is a little researched topic, only a few articles can be found in this area. In most cases, the publications focus the development of a test mould or an adhesion test, or the analysis of the adhesion between different overmoulded materials [11-14]. Therefore, the aim of our work was to analyse the bonding strength of the overmoulding process. First, we analysed the effect of the main injection moulding parameters (melt temperature and holding pressure) on unfilled samples. After that, unfilled polypropylene was overmoulded on samples filled with glass fibre and glass beads, and the effect of these fillers was analysed. We used a special grip in the evaluation of bonding strength and explained the results using microscopic images.

2. Materials and methods

2.1. Materials

For the matrix, we used Tipplen H145 F homopolymer polypropylene (PP) (MOL Petrochemicals Co. Ltd., Hungary). The reinforcement was Camelyaf BMC-1 (Şişecam Chemicals Group, Turkey) 6 mm long chopped glass fibre (GF). We also used glass beads (GB) (Cerablast GmbH & Co. KG, Germany) in two different sizes to make PP/GB compounds. According to the producer, the chemical composition of the GB is the following: SiO₂: 68–75%, Na₂O: 12–18%, CaO: 7–12%, MgO: max. 5%, Al₂O₃: max. 2.5%, K₂O: max. 1.5% and Fe₂O₃: max. 0.5%.

2.2. Sample preparation

First, we prepared the compounds of the preforms for the overmoulding tests. Polypropylene with 30 m% glass fibre was compounded on a Labtech LTE 25-30/C (Labtech Engineering Co., Ltd., Thailand) single-screw extruder. We used a single-screw extruder to minimize the breakage of the reinforcement and fillers. The temperature of the zones were 210 °C; 205 °C; 200 °C and 195 °C, the temperature of the die was 210 °C and screw rotation speed was 25 1/min. The PP/GB compounds were prepared in the same way, but before compounding we separated the beads into two fractions (75-125 µm and 125-250 µm) with a Cisa BA 200N sieve shaker (CISA Cedaceria Industrial, Spain). PP/GB compounds were produced with 10 m%, 25 m% and 40 m% GB concentration.

After that the 80 mm x 80 mm x 2 mm flat preforms were injection moulded from the compounds with an Arburg Allrounder 370 S 700-290 injection moulding machine. The main injection moulding parameters of the preforms can be found in Table 1.

Table 1 Injection moulding parameters

Melt temperature	Value	Unit
Temperature of the heating zones	210, 210, 205, 200, 195	(°C)
Mould temperature	40	(°C)
Volume	48	(cm ³)
Switchover point	6.6	(cm ³)
Holding pressure	800	(bar)
Holding time	20	(s)
Injection rate	20	(cm ³ /s)
Plasticizing speed	20	(m/min)

The overmoulding tests were performed with a special mould (Figure 1), presented in our earlier paper [14]. With this special cold runner tool, we can overmould a 70 x 50 mm rib onto the 80x80 mm preforms. We placed two pressure sensors and three temperature sensors near the bonding area. The temperature of the mould can be controlled with a temperature controller up to 100 °C. During the overmoulding test, mould temperature was 40 °C, the injection rate was 20 cm³/s and holding time was 5 s. Melt temperature and holding time were varied according to the DoE (Design of experiments) presented in the next chapter.

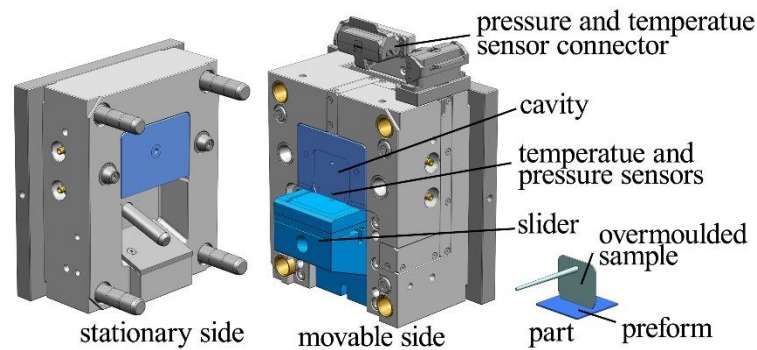

Figure 1 Special mould for overmoulding test

2.3. Design of Experiments

We performed three different designs of experiments to analyse interfacial adhesion between the preforms and the overmoulded material. In the first experiment, melt temperature and holding pressure were varied, as these can affect adhesion. During the tests, the other parameters were kept constant.

Table 2 DoE for analysing the effect of the main injection moulding parameters

Settings	Melt temperature (°C)	Holding pressure (bar)
Melt temperature test	190; 215 or 240	450
Holding pressure test	215	250; 450 or 650

In the second experiment, the effect of the reinforcement was analysed. First the unfilled polypropylene was overmoulded on unfilled flat preforms, then the unfilled PP was joined to the polypropylene preforms filled with 30 m% glass fibre. The tests were performed at three different melt temperatures: 190 °C, 215 °C and 240 °C.

During the third DoE, the unfilled PP was overmoulded on glass bead-filled polypropylene samples. In this experiment, glass bead sizes and filler concentration were varied. The first bead size was between 75 and 125 μm , and the second was between 125 and 250 μm . Melt temperature was 215°C and holding pressure was 450 bar.

2.4. Characterization of the samples

Bonding strength was analysed with the use of a special grip (Figure 2.) in tensile test mode, designed for the T-shaped injection moulded samples. The tensile tests were performed on a Zwick Z020 (Zwick GmbH & Co. KG, Germany) universal testing machine. During the tests, the injection moulded samples were laid upside down on the upper plate and the overmoulded rib was put into the gap of the plate. After that the rib was clamped with a grip. Then the upper half of the grip was displaced vertically. We determined bonding strength (tear-off strength) by dividing the maximum tear-off force with the connecting surface area (120 mm²).

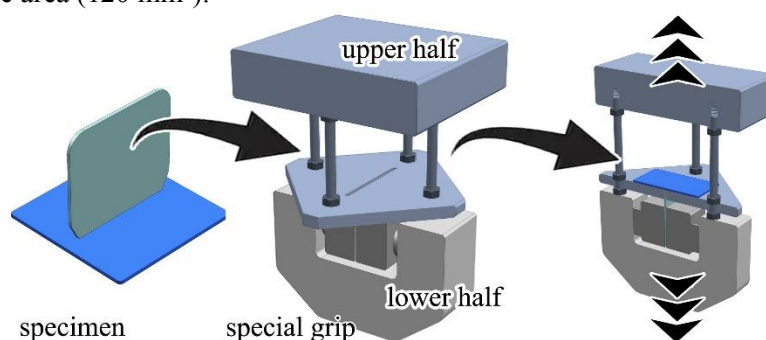

Figure 2 Special tool to measure the tear-off strength

The fracture surfaces of the samples were analysed with a JEOL JSM 6380LA scanning electron microscope (SEM) (Jeol Ltd., Japan). Before the analysis, the surface of the samples was gold spur coated with a JEOL FC 1200 device. Glass bead distribution was analysed with a Keyence VHX-5000 (Keyence Corporation, Japan) optical microscope.

3. Results and discussions

3.1. Effect of the injection moulding parameters

First, the samples were injection moulded in the special overmoulding mould without preforms—these were the reference samples. The tensile tests carried out on these samples yielded the reference bond strength, which was 28.8 ± 0.24 MPa.

As a next step, we analysed the effect of melt temperature on bonding strength between the unfilled PP preform and the PP material (Figure 3/a). As melt temperature increased, bonding strength also increased significantly. At a low melt temperature (190 °C) the tear-off strength was very low, only 5.1 MPa, while at a melt temperature of 240 °C, tear-off strength was 14.7 MPa strength, which is still 50% lower than that of the reference sample. The reason for this could be that at higher melt temperatures, the temperature of the preform will be closer to its melt temperature, hence molecular connections are more perfect. For bonding, the surface of the preform must reach a high enough temperature for a melt layer to form. This way, the polymer molecules can diffuse across the interface (intermolecular diffusion). At a low temperature, the thickness of the melt layer is low. As melt temperature is increased, the melt layer becomes thicker and more molecular movement can be achieved.

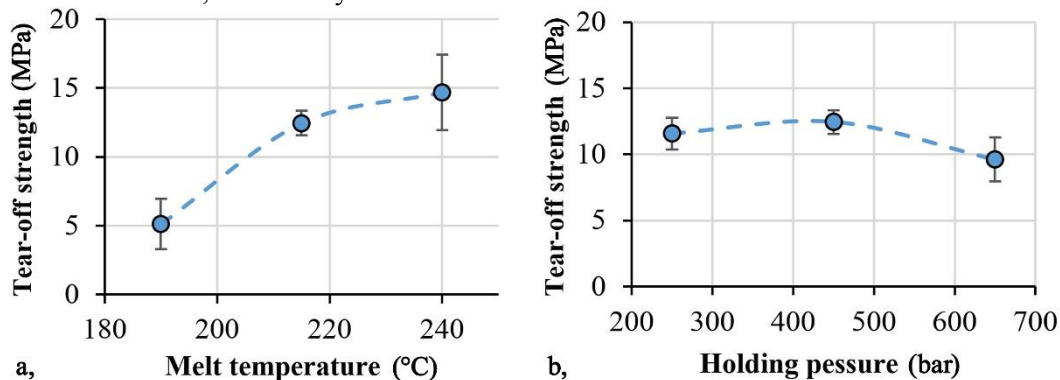

Figure 3 Bonding strength as a function of melt temperature (a) and holding pressure (b)

In the second step, we analysed the effect of holding pressure (Figure 3/b). The theory was that at higher pressures heat transfer between the surfaces is increased, hence the surface temperature of the preform and the thickness of the melt layer are also increased. This way, intermolecular diffusion is improved across the interface. Holding pressure was analysed at three levels (250, 450 and 650 bar) and was maintained for 5 seconds. Actual pressures (Figure 4.) during injection moulding were captured with cavity pressure sensors near the bonding area. Cavity pressures were about 100-150 bar lower than holding pressure set on the machine. Tear-off strength varied between 9.6 and 12.4 MPa. At low pressures (between 250 and 450 bar), the average tear-off strength increased according to the theory. Contrary to expectations, bonding strength decreased slightly at the highest pressure (650 bar); it is probably caused by residual stresses.

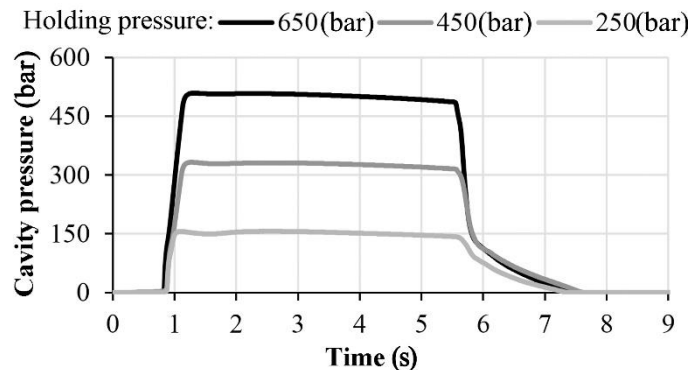

Figure 4 Cavity pressure next to the bonding surface as a function of holding pressure

3.2. The effect of the reinforcements

The effect of the glass fibre reinforcement on bonding strength was also analysed at three melt temperatures. At the lowest melt temperature (190 °C), tear-off strength was very weak; in most cases the preform and the overmoulded part separated right after clamping during the mechanical test. Average tear-off strength was about 1.2 MPa. As melt temperature increases, binding strength also increases. When melt temperature was 215 °C and 240 °C, bonding strength was 5.6 MPa and 9.8 MPa, respectively. As Figure 5 shows, the reinforcement significantly decreased bonding between the components—the difference is between 4–7 MPa. The reason for this could be that there are fibres on the surface of the preform, and connection between the fibres and the matrix is weak, hence adhesion decreases. At low melt temperature, the GF decreased strength by 75%, and at 240 °C by 35%. We found that the relative difference between the unfilled polymer and GF reinforced composites decreased when melt temperature increased. These results show the positive effect of the melt temperature.

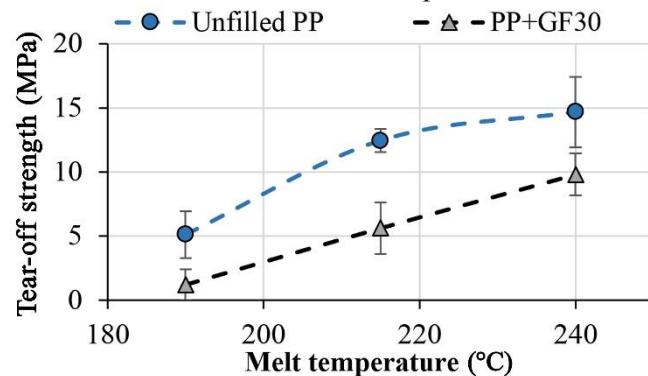

Figure 5 Tear-off strength in the case of unfilled and 30 m% glass fibre-reinforced polypropylene

3.3. The effect of glass beads

The effect of glass bead size was analysed at three different filler concentrations (10, 25 and 40 m%). With an increase in the amount of glass beads, tear-off strength decreases (Figure 6). When we overmoulded on the unfilled plates, a 12.4 MPa tear-off strength was measured. With the small glass beads 9.1 MPa, 9.15 MPa and 5.6 MPa and with the larger beads 10.4 MPa, 10.6 MPa and 8.3 MPa bonding strength was measured at GB concentrations of 10 m%, 25 m% and 40 m%. With smaller beads, average strength is also lower. The reason may be the segregation of the fillers, which was shown by microscopic analysis. The segregation of fillers means an inhomogeneous distribution of particles. This inhomogeneity can be created either along the flow path or in the cross section of the part. In our case, segregation in the cross section can cause bonding problems.

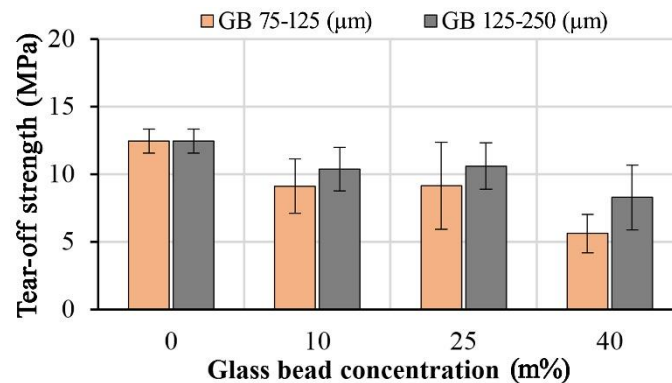

Figure 6 Tear-off strength as a the function of glass bead concentration and glass bead size

SEM images were taken about the fracture surface of the specimens (Figure 7). As the figure shows, a higher amount of glass beads can be found on the fracture surface in the case of smaller glass beads (Figure 7/a) than in the case of larger beads (Figure 7/b). When smaller particles are used, the segregation effect can be neglected. Hence the glass beads can be distributed homogeneously. When larger beads are used, segregation is more pronounced. During the filling of the cavity, a thin frozen layer develops next to the cavity wall. The flowing melt can easily tear the larger particles out of the frozen layer. In consequence, a thin layer with fewer particles evaluated near the surface.

As interfacial adhesion is weak between the filler and the matrix, the beads act as failure locations. The higher the number of glass beads close to the surface, the lower the effective bonding surface in the part. The difference between the inhomogeneous filler distributions of different glass bead sizes along the cross section of the specimen was also proved with optical microscopic images (Figure 8).

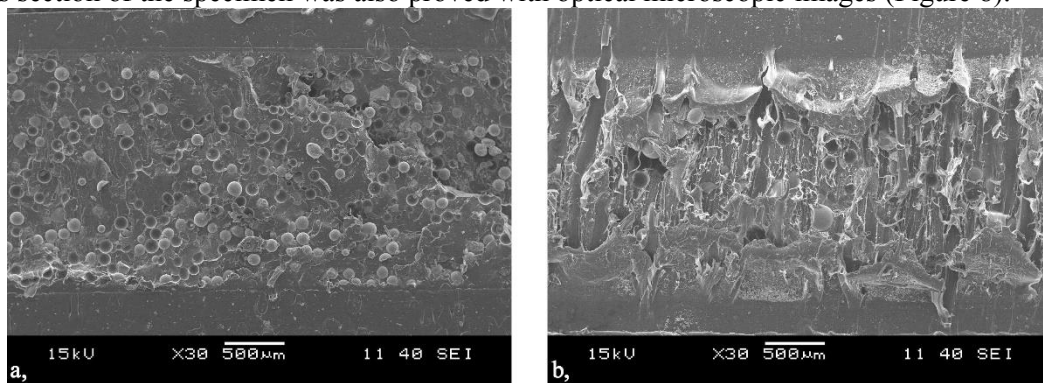

Figure 7 Electron microscopic images of 75-125 μm (a) and 125-250 μm (b) glass bead-filled polypropylene samples (PP+GB40)

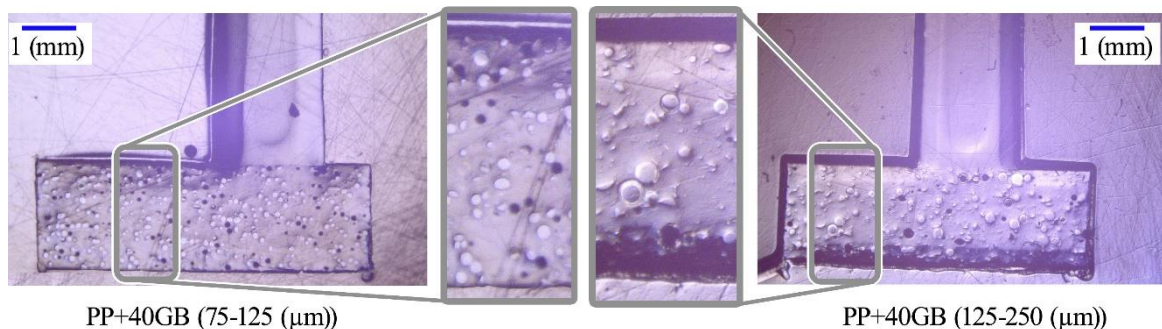

Figure 8 Microscopic images of the cross section of 75-125 μm and 125-250 μm glass bead filled polypropylene samples (PP+GB40)

4. Conclusions

We analysed the effect of glass fibre and glass beads on the bonding strength between the components of multicomponent injection moulded parts. We prepared seven different polypropylene-based glass fibre-reinforced and glass bead-filled compounds, then injection moulded 80 mm x 80 mm x 2 mm flat preforms from them. With a special mould, unfilled polypropylene was overmoulded on the preforms, and tear-off strength was measured by tensile tests. We also analysed the effect of technological parameters on unfilled specimens. We found that holding time does not have a remarkable effect on bonding strength, but with increasing melt temperature, bonding strength increased significantly. It can be explained with the thickness of the melt layer on the surface of the preform and with intermolecular diffusion. When 30 m% glass fibre was added to the matrix, bonding strength decreased. The reason is the presence of the fibres in the surface layer, which act as failure locations when interfacial adhesion is weak between the fibres and the matrix. The glass beads also have a negative effect on the bonding strength between the components of multicomponent parts. When smaller glass beads were used, strength decreased further. We explained it with the segregation of the fillers in the cross section of the preforms, which we proved with microscopic images.

Acknowledgements

The project is funded by the (NKFIH) National Research, Development and Innovation Office (NVKP_16-1-2016-0038, 2017-2.3.7-TÉT-IN-2017-00049, 2018-1.3.1-VKE-2018-00001) and by the National Research, Development and Innovation Fund (TUDFO/51757/2019-ITM, Thematic Excellence Program). It was supported by the ÚNKP-19-4 New National Excellence Program of the Ministry for Innovation and Technology. This paper was supported by the János Bolyai Research Scholarship of the Hungarian Academy of Sciences. The authors would like to thank Arburg Hungaria Ltd. for the injection moulding machine.

References

- [1] Osswald T et al 2001 *Injection Molding Handbook* (Munich: Hanser)
- [2] PlasticEurope 2018 *Plastics – the Facts 2018*. 1-60
- [3] Xie L and Ziegmann G 2011 *J. Alloys Compd.* **509** 226-233
- [4] Karsli N G et al 2014 *Compos. Part B – Eng.* **63** 154-160
- [5] Tábi T et al 2015 *Express Polym. Lett.* **9** 394-400
- [6] Tábi T et al 2014 *Compos. Part A – Appl. Sci.* **64** 99-106
- [7] Kovacs J G and Suplicz A 2013 *J. Reinf. Plast. Comp.* **32** 1234-1240
- [8] Dzulkipli A A and Azuddin M 2017 *Procedia Engineer.* **184** 663-672
- [9] Ebnesajjad S 2011 *Handbook of adhesives and surface preparation* (Oxford: Elsevier)
- [10] Awaja F et al 2009 *Prog. Polym. Sci.* **34** 948-968
- [11] Joppich T et al 2017 *Proc. CIRP* **66** 137-142
- [12] Carella A R et al 2002 *Polym. Eng. Sci.* **42** 2172-2181
- [13] Boros R et al 2018 *Materials* **11** 2140
- [14] Boros R et al 2019 *Express Polym. Lett.* **13** 889-897